



Getting started with VnR

Starting out

The Modelling package has to be accessed directly from folders on the CD ROM. If you are unsure how to find folders on your computer you will need assistance.

You need

- A modern browser (e.g. Internet Explorer, Netscape) to read the help files within the Modelling programme. If you cannot access the help files from here, browse the sycd folder, open the modelling then VnR folders, and double click Start Here.
- Java runtime software. To install this:
 - **Windows**
Install Java runtime edition 1.3.1 on your computer by double clicking on **j2re-1_3_1_02-win.exe**.
This can be found in the modelling folder within the sycd folder on this CD ROM.
 - **MacOS**
None is necessary for MacOSX.
For Mac OS9 and below the version of Java required is not available.
 - **Other operating systems**
Visit **www.sun.com/** to see if the appropriate version of Java is available for your platform of choice.
Download it and install onto your machine.

All systems

- 1 Copy the Modelling folder onto hard disks of individual machines as required.
- 2 Install Java runtime software as above. Locate the file **vnR.jar** inside the folder VnR.
- 3 Double click on this file to launch the programme.

More help

Single-side summaries for building and help are provided below as:

- **VnR-build in one**

- **VnR-run in one**

On-line help

Step by step instructions. If you cannot access the help files from within Modelling, browse the sycd folder, open modelling then VnR folders, and double click Start Here.

Activities

A few activities are provided to get you started. These have teacher and pupil guides and teacher tips and are accessible from the help menu.

Models

Ready-made models to support the Activities are in the models folder.

- **car_movement.vnr**

- **force_switch.vnr**

- **underwater.vnr**

Version 0.08

This software is work in progress, over the duration of Science Year.

Currently several tool buttons and menu items are greyed out, indicating that this part is not yet completed.

Since the software is in development your feedback would be appreciated – particularly any ‘Lesson stories’.

1 Issues

Things that the modelling tool does not do, perhaps confounding your expectations, or that you would like it to do.

For these please attach a model to the e-mail and use the body of the email to explain how the model fails to fulfil your expectations. No reply is guaranteed, but everything will be read.

Please e-mail these to

I.Lawrence@bham.ac.uk
with ‘VnR issue’ in the subject line.



Known (major) issues at present include:

- 1 cursors scale to 16 by 16 under MacOSX. Not pretty!
- 2 calculated values can sometimes become locked at zero. Stop/ pause, and then drag the variable, can unlock them
- 3 switch values need adjusting
- 4 the integration engine produces runaway solutions if the rates of change are large
- 5 some menu and button items are not implemented yet (greyed out).

2 Lesson stories

Ways of sharing good practice

This is a new tool, and people will think of many ways to use it.

Please attach a model to the e-mail, as a partial illustration of the purposes that the tool has served. Please then complete the story in the body of the e-mail, using the following pattern to make the story as useful to others as possible.

- 1 name of model file
- 2 topic
- 3 year group
- 4 outline of lesson
- 5 sketch of how the model contributed to the lesson
- 6 your name and position.

It is likely that some of these will be useful to others, to help them see possibilities. Please say whether you are willing to have this contribution made available to others on the web, appropriately credited.

Please e-mail these to

I.Lawrence@bham.ac.uk
with ‘VnR lesson’ in the subject line.



Teacher's view of nearly everything

Build

use this pair to switch between running and building

choose select tool then:

drag to move

click on any piece of text in the model to change it

right click (Windows) or control click (MacOS) to set how the contributions combine

right click (Windows) or control click (MacOS) to put a relationship to sleep

drag to set value

choose, then click on workspace to place variables that

are positive only

can have any value

choose, then click on output, followed by input, to link a pair of variables by a relationship that is

a rate (accumulates)

a value (sets level)

an 'on above' switch

an 'on below' switch

choose, then click to delete

Run

use this pair to switch between running and building

click to play the model

click to stop the model

drag to set value

right click (Windows) or control click (MacOS) to set how the contributions combine

right click (Windows) or control click (MacOS) to put a relationship to sleep

Building your first model

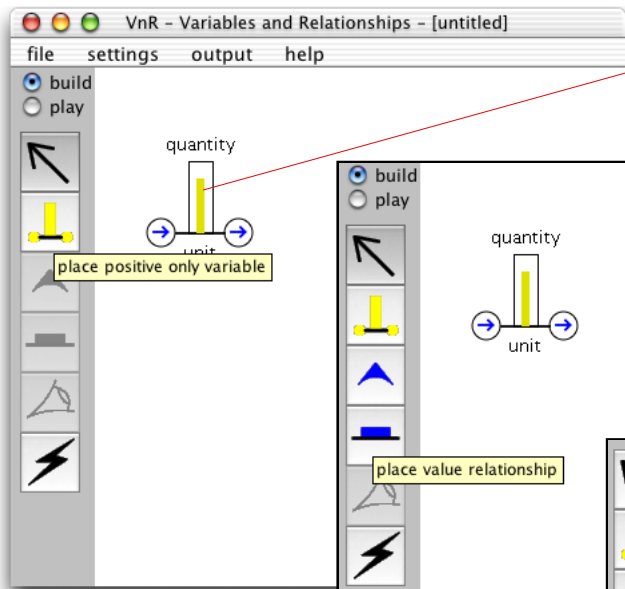

Click once to place a variable

Click again to place another variable

Click to choose this relationship

Click to start the link

Click to finish the link

Right click (Windows) or control click (MacOS) to set the strength and sense of the relationship

Repeat the steps above to place another variable and link it with the same kind of relationship

Right click (Windows) or control click (MacOS) to set how the contributions combine

Optional: click on any piece of text in the model to change it

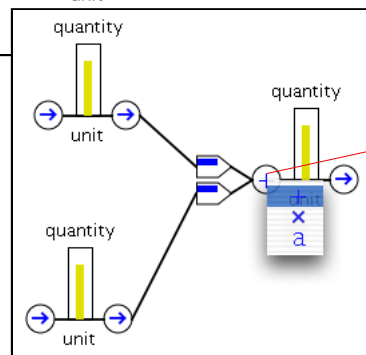
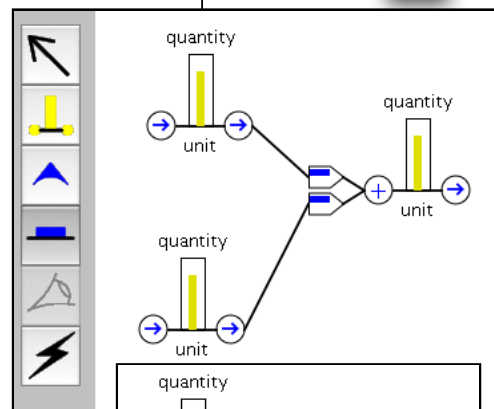
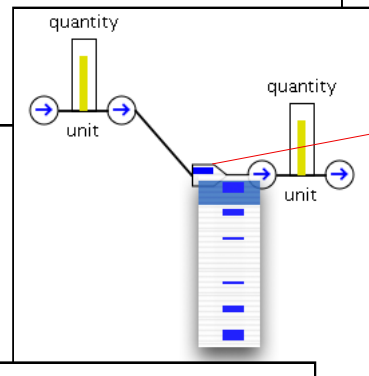
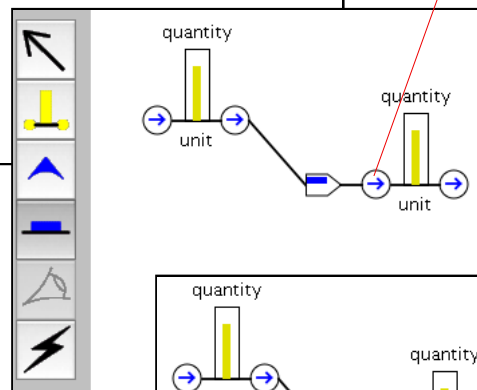
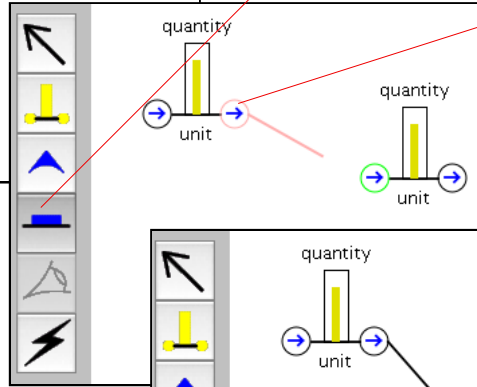
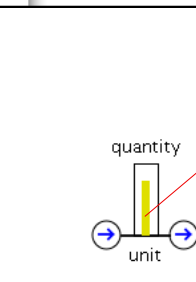
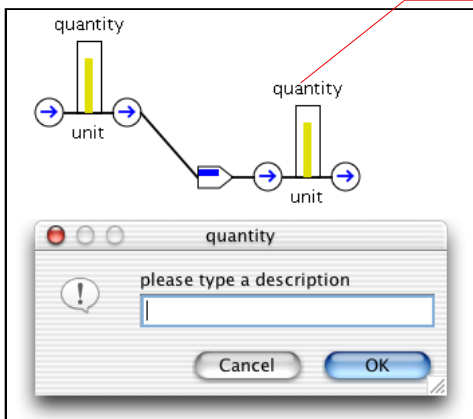

Running your first model

Click to run the model

Click to stop the model

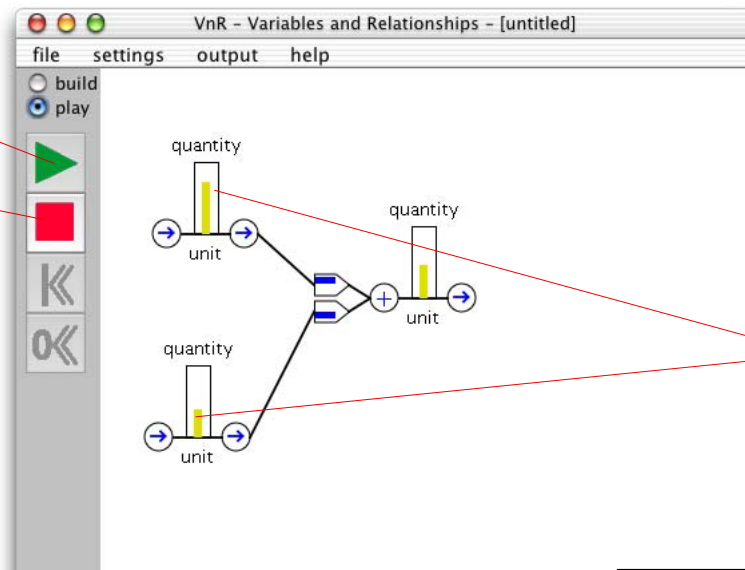

Drag either to set the values

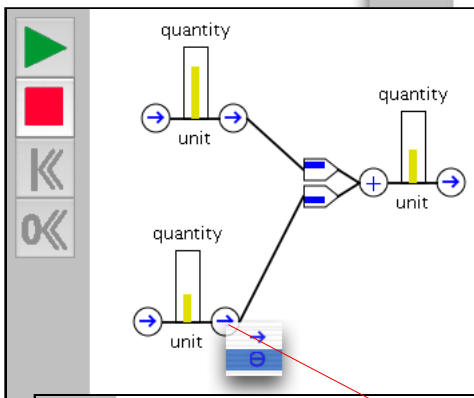

Right click (Windows) or control click (MacOS) to put a relationship to sleep

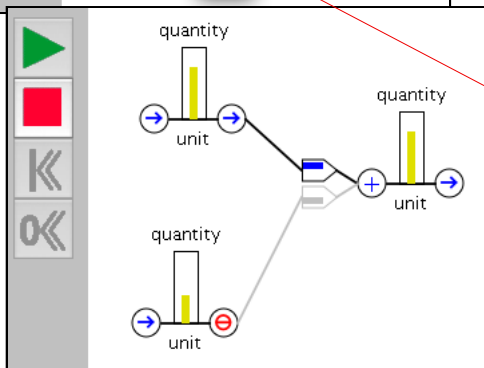

Right click (Windows) or control click (MacOS) to set how the contributions combine

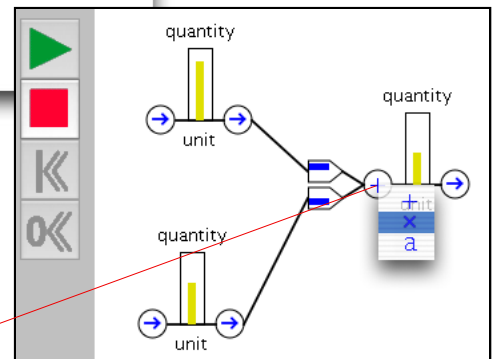

Right click (Windows) or control click (MacOS) to set the strength and sense of the relationship

